

Electric Druid VCLFO

Introduction	1
<i>Block diagram</i>	1
Features	2
<i>Fastest LFO frequency of around 12.8Hz</i>	2
<i>Slowest LFO frequency of around 0.05Hz</i>	2
<i>10-bit LFO output resolution</i>	2
<i>19.5KHz sample output rate</i>	2
<i>8-bit resolution on the control voltages</i>	2
<i>Logarithmic control response over 1:256 range</i>	2
<i>8 output waveforms</i>	2
<i>Sample-and-Hold</i>	2
<i>Wave Distortion CV input</i>	3
<i>Ability to sync LFO and S&H</i>	3
Pinout Diagram	4
Application Notes	5
<i>Basic circuit diagram</i>	5
<i>Using potentiometers for CVs</i>	6
<i>External 1V/Oct CV inputs</i>	6
<i>Sync Mode CV from Switch</i>	6

Introduction

This voltage-controlled low frequency oscillator uses a PIC microprocessor to create a versatile LFO. All LFO parameters can be controlled by 0-5V control voltages so that the chip can easily be interfaced with a programmer.

Block diagram

The chip can produce 7 oscillator waveforms and also has a noise source and a sample-and-hold. The basic LFO frequency is controlled by FREQ CV. The WAVEFORM voltage selects one of the 8 waveforms to be fed to the sample-and-hold. This has its own rate set by STEP RATE CV, and can be disabled entirely. The LFO wave shapes can be modified by the WAVE DISTORT CV. Finally, the LEVEL CV sets the output level.

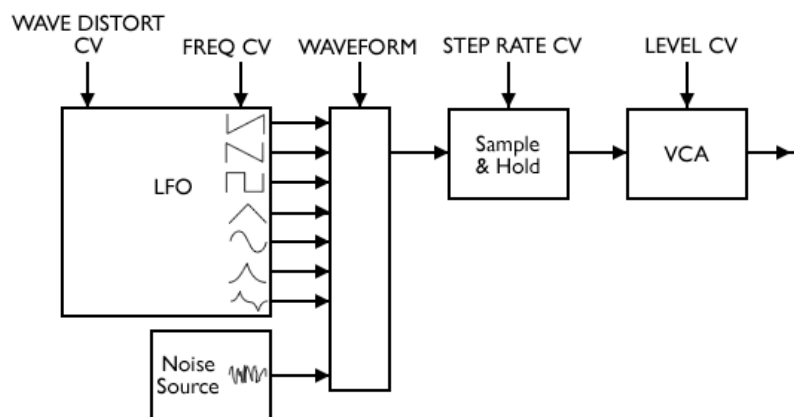

Features

Fastest LFO frequency of around 12.8Hz

The LFO can produce an output all the way into low audio frequencies.

Slowest LFO frequency of around 0.05Hz

Most analogue synths can do a slow modulation wave down to about 0.1Hz. This gives a 10 second cycle time. This LFO goes an octave lower, so that you can produce long sounds that continue to evolve for ages (0.05Hz is 20 secs).

10-bit LFO output resolution

The internal waveforms and calculations are 8-bit, but the final LEVEL_CV multiplication provides a 16-bit output, of which 10 bits are fed to the PWM module.

19.5KHz sample output rate

The PWM frequency is around 19.5KHz. This allows the PWM output to be heavily filtered for a smooth analogue output. The two-stage 24dB Bessel filter provides the best-possible pulse filtering.

8-bit resolution on the control voltages

The Sequential Prophet 5 used a 7-bit control resolution, so this is going slightly better. Whether a standard potentiometer actually has the accuracy to directly produce an 8 bit resolution is another question. The inputs are sampled at over 6KHz.

Logarithmic control response over 1:256 range

The frequency CV gives the full range from 0.05 Hz to 12.8 Hz in eight even octaves, eg 0.05-0.1Hz, 0.1-0.2Hz, 0.2-0.4Hz, 0.4-0.8Hz, 0.8-1.6Hz, 1.6-3.2Hz, 3.2-6.4Hz, 6.4-12.8Hz. The fact that this input is logarithmic means the FREQ CV input can easily be scaled to the IV/Oct CV standard, although the LFO's FREQ CV resolution is only 32 steps per octave.

8 output waveforms

The chip can produce 8 output waveforms, shown below. These are selected by the voltage on Pin 12 (WAVEFORM).



Sample-and-Hold

The selected waveform can be further modified by the sample-and-hold module. With Pin 11 (STEP RATE CV) below approximately 0.157V (a AD reading of 8), this feature is disabled. Higher voltages set the rate for the sample-and-hold. Note that the sample-and-hold rate is only updated when the current step is finished, so if a slow rate has been selected, it can take a moment to change to a faster rate.

Wave Distortion CV input

The selected waveform can be distorted using the WAVE DISTORT input. This regards each waveform as consisting of two equal sections - with a square wave, these would be the high and low parts respectively. Usually each section occupies 50% of the waveform's total length, but the WAVE DISTORT input allows you to modify this until one half of the wave occupies almost all the time.

This is better seen with a diagram:

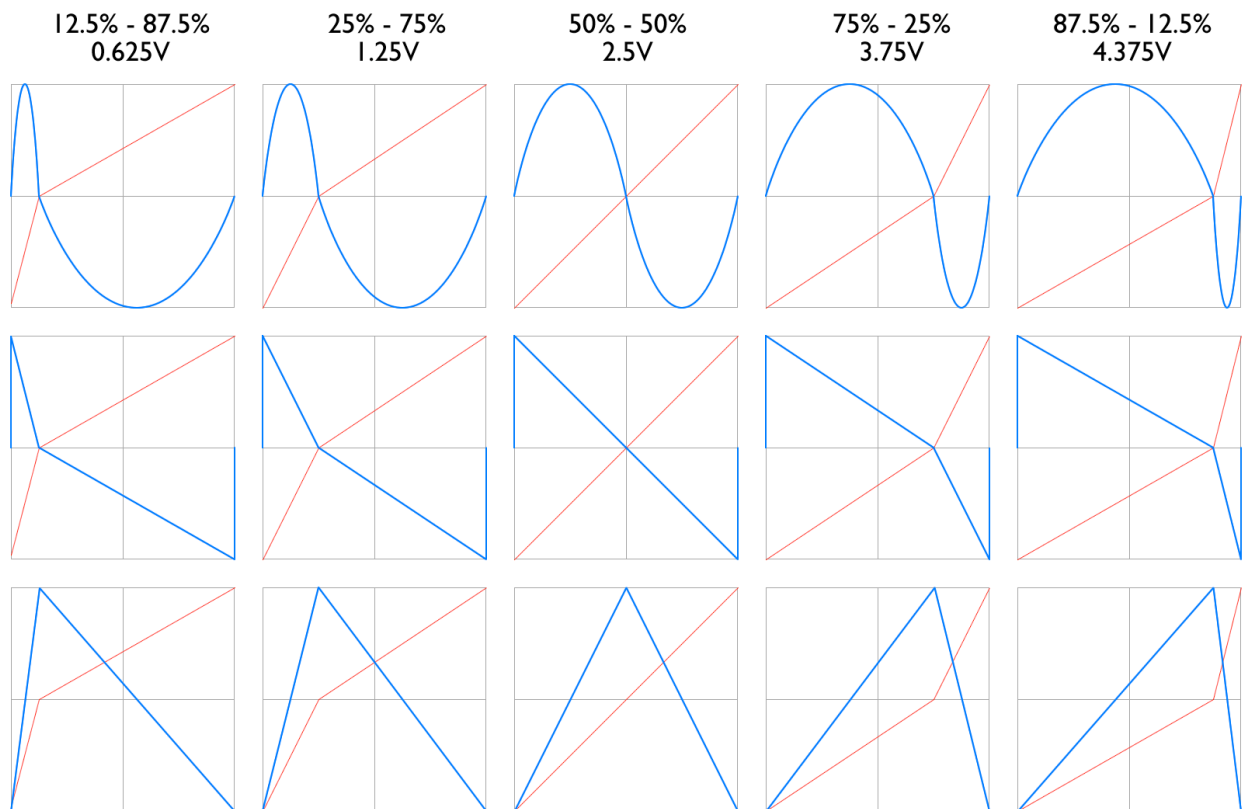

The top row shows the effect of the WAVE DISTORT CV on the SINE wave, whilst the following rows show the effect on the RAMP DOWN and TRIANGLE waveforms. Other waves (excepting NOISE) are affected similarly.

Ability to sync LFO and S&H

The SYNC IN input allows you to use a 0-5V pulse signal to reset the phase of either the LFO or the S&H. The SYNC IN MODE input voltage selects either LFO, S&H, or both to be reset by the SYNC IN pulses.

Note that this input provides hard synchronization of the LFO and S&H, and is not an external clock. The effect of an externally-clocked S&H can be achieved by setting a very slow S&H rate with a faster SYNC IN pulse rate.

Pinout Diagram

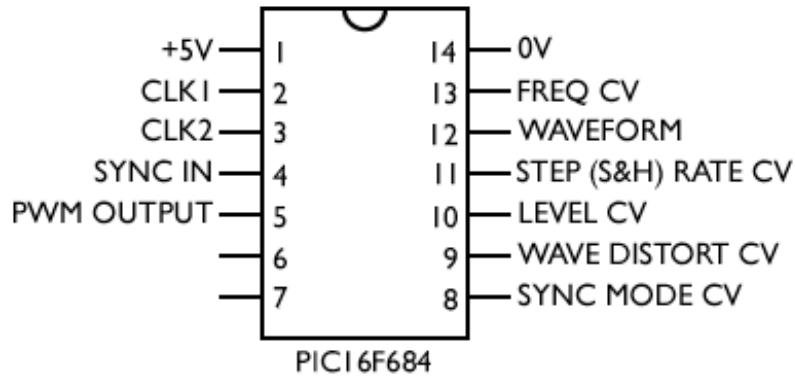

Pin	Function	Details	Notes
1	+5V	Power supply	
2	CLK1	Connect to Xtal	20Mhz Clock
3	CLK2	Connect to Xtal	20Mhz Clock
4	SYNC IN	0-5V digital input	Can reset either LFO, S&H, or both
5	PWM OUTPUT	0-5V digital output	PWM output at 19.5KHz
6	Unused		
7	Unused		
8	SYNC MODE CV	0-5V analogue input	2-bit, values from 0 to 3 0 - Sync disabled 1 - Reset S&H 2 - Reset LFO 3 - Reset both
9	WAVE DISTORT CV	0-5V analogue input, with 2.5V offset	8 bit, values from 4 to 252 Produces phase distortions of the waveform
10	LEVEL CV	0-5V analogue input	8 bit, values from 0 to 255 Controls overall output level
11	STEP RATE CV	0-5V analogue input	8 bit, values from 8 to 255 (Below 8 is off) 0.1 Hz to 25 Hz
12	WAVEFORM	0-5V analogue input	3 bit, values from 0 to 7
13	FREQ CV	0-5V analogue input	8 bit, values from 0 to 255 0.05 Hz to 12.8 Hz
14	0V	Power supply	

Application Notes

Basic circuit diagram

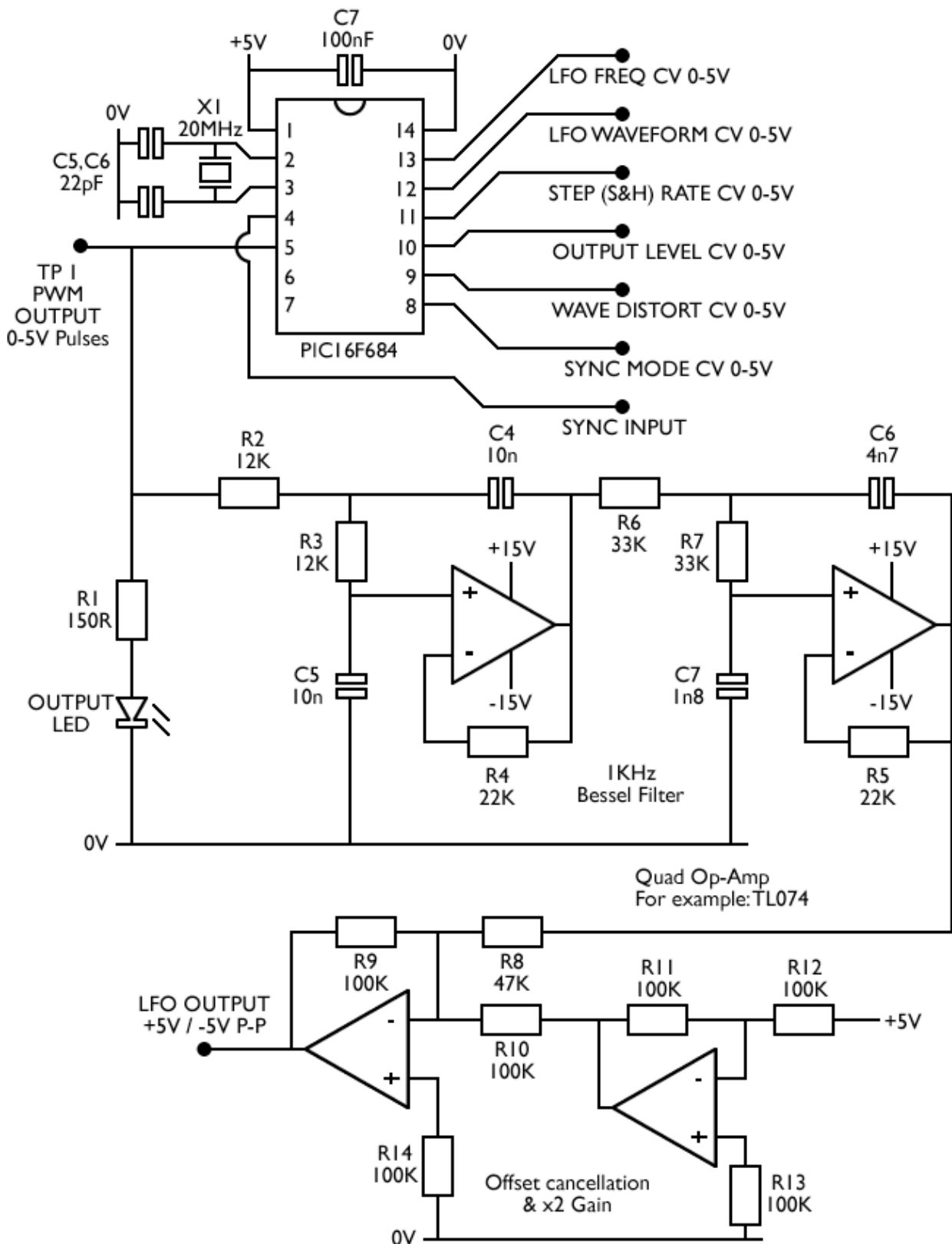

If exact adjustment of offset or output level is required, R8 (level) and/or R10 (offset) can be replaced with trimmers.

Using potentiometers for CVs

The required control voltages can be produced directly from potentiometers as follows:

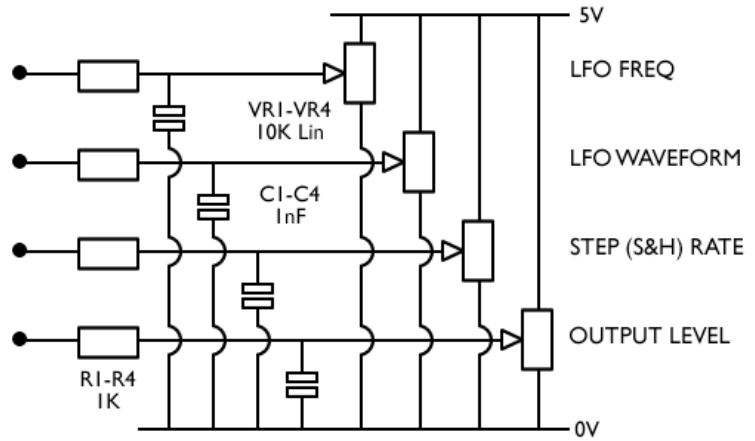

External IV/Oct CV inputs

External IV/Oct CV inputs can be combined with the Frequency control by using a couple more op-amps. These inputs have a maximum range of 0-8V (8 octaves), and a resolution of 32 steps/octave.

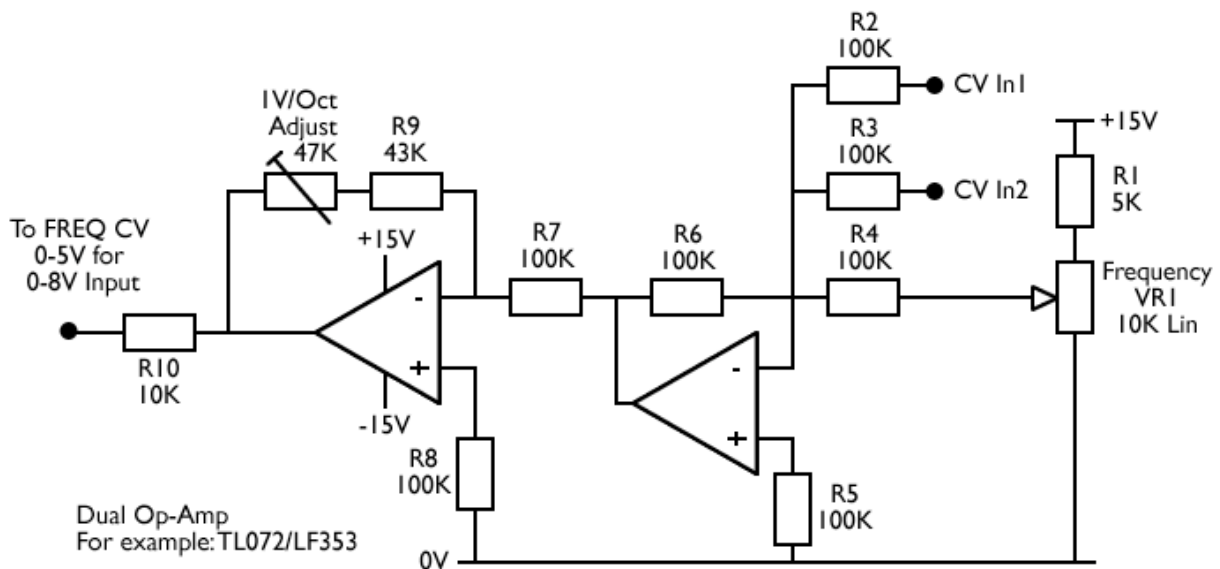

A similar circuit will provide a mixture of external and internal control for the WAVE DISTORT CV.

Sync Mode CV from Switch

The SYNC MODE CV can either be generated by a pot as above, or selected using a 4-position switch.

